

### Question block created by wizard

This exam contains 92 questions.

1. Newton's first law states:

- (a) When a body is acted upon by an external force, the rate change of momentum is proportional to the force and takes place in the direction of the force.
- (b) A body will remain at rest or will continue in uniform motion in a straight line unless acted upon by force.
- (c) To every action there is an opposite and equal reaction.

*If choice b is selected set score to 1.*

2. What is mechanical work?

- (a) The cause to accelerate a mass.
- (b) The amount of energy transferred by a force.
- (c) The rate at which work is performed or energy is transmitted.

*If choice b is selected set score to 1.*

3. Name the modules (parts) of a jet engine from front to rear .

- (a) Turbine wheel, compressor and combustion chamber.
- (b) Air compressor, combustion chamber, turbine wheel, and exhaust duct.
- (c) Air compressor, combustion chamber, cylinders and exhaust duct.

*If choice b is selected set score to 1.*

4. The difference in operation between a propeller and a jet engine can be summarized as follows:

- (a) A propeller accelerates a large quantity of air rearwards at a low rate. A jet engine accelerates a small quantity of air rearwards at a high rate.
- (b) A propeller accelerates a large quantity of air rearwards at a high rate. A jet engine accelerates a small quantity of air rearwards at a low rate.
- (c) Propeller is pulling while a jet engine is only compressing air.

*If choice a is selected set score to 1.*

5. In what unit is the engine output power of a turbojet normally measured?

- (a) Thrust lbs or kg.

- (b) Turbopower.
- (c) Jet thrust.

*If choice a is selected set score to 1.*

**6.** Thrust of a gasturbine engine comes from....

- (a) the acceleration of the air and fuel molecules.
- (b) the pressure of the exhaust against the atmosphere.
- (c) the enormous suction at the engine inlet.

*If choice a is selected set score to 1.*

**7.** When all factors are combined, it is found that the jet aircraft performs most efficiently at...

- (a) high speeds and low altitudes.
- (b) low speeds and high altitudes.
- (c) high speeds and high altitudes.

*If choice c is selected set score to 1.*

**8.** The bypass ratio of a modern turbofan is....

- (a) around 2 : 1.
- (b) around 5 : 1.
- (c) around 8 : 1.

*If choice c is selected set score to 1.*

**9.** Air velocity at the inlet of the low pressure compressor must be around....

- (a) Mach 0.1
- (b) Mach 0.5
- (c) Mach 0.9

*If choice b is selected set score to 1.*

**10.** What will happen in flight if the intake airspeed increases?

- (a) Thrust will decrease.
- (b) Thrust will not change.
- (c) Thrust will increase.

*If choice b is selected set score to 1.*

**11.** During flight, the distribution of static pressure in and around the engine is as follows:



- (a) A: Low Pressure, B: High Pressure, C: Low Pressure
- o (b) A: High pressure, B: Low pressure, C: High pressure
- o (c) A: Low pressure, B: Low pressure, C: High pressure

*If choice a is selected set score to 1.*

**12.** Why are methods like diverter, fence and bleed used?

- o (a) To restrict the amount of airflow at supersonic speeds.
- (b) To avoid boundary layer effect in the intake.
- o (c) To increase the efficiency of the intake at low (subsonic) speeds.

*If choice b is selected set score to 1.*

**13.** What is the most effective intake shape for supersonic speeds?

- o (a) Divergent - convergent duct.
- o (b) Straight duct.
- (c) Convergent - divergent duct.

*If choice c is selected set score to 1.*

**14.** What type of anti-icing system is generally installed on turboprop engines?

- o (a) Hot air anti-ice
- o (b) Pneumatic anti-ice
- (c) Electrical anti-ice

*If choice c is selected set score to 1.*

**15.** How is the hot air anti-ice system activated?

- o (a) The system is always on and can not be switched off
- (b) Manually from the flightdeck
- o (c) Automatically when ice is detected

*If choice b is selected set score to 1.*

**16.** In the axial compressor the flow of air is maintained parallel to...

- o (a) the compressor centers around the impeller, diffuser and air intake system.
- o (b) the vertical rotation of the compressor blades.

- (c) the compressor shaft.

*If choice c is selected set score to 1.*

**17.** Many aircraft APU's use a centrifugal hardware configuration because of its...

- (a) compact size.
- o (b) high power development and ability to support various support system.
- o (c) high overall compression ratio.

*If choice a is selected set score to 1.*

**18.** Fan blades can be removed and replaced, however the replaced blade must be of the....

- (a) same moment and weight class.
- o (b) same color code.
- o (c) production batch.

*If choice a is selected set score to 1.*

**19.** What is an advantage of the Wide Chord Fan Blade Technology?

- o (a) Increase weight.
- o (b) Much longer life of operation.
- (c) The number of blades can be reduced.

*If choice c is selected set score to 1.*

**20.** What can cause a compressor stall or surge?

- (a) A rapid throttle movement.
- o (b) A low take off speed.
- o (c) A high speed landing.

*If choice a is selected set score to 1.*

**21.** Compressor bleed control valves are normally spring loaded to the...

- o (a) mid-range position.
- (b) open position.
- o (c) closed position.

*If choice b is selected set score to 1.*

**22.** The term "overall pressure ratio" is defined as the ratio of the...

- (a) stagnation pressure at the combustion chamber.
- (b) pressure at the front and rear of the compressor of a gas turbine engine.
- (c) stagnation pressure due to the rotor speed of the shafts against the compressor inner wall.

*If choice b is selected set score to 1.*

**23.** The compressor outlet delivers compressed air, to a component in front of the combustion section.

How do you call this?

- (a) The exhaust section of the compressor.
- (b) Nozzle section.
- (c) Diffuser.

*If choice c is selected set score to 1.*

24. What kind of combustion system is shown in the picture?

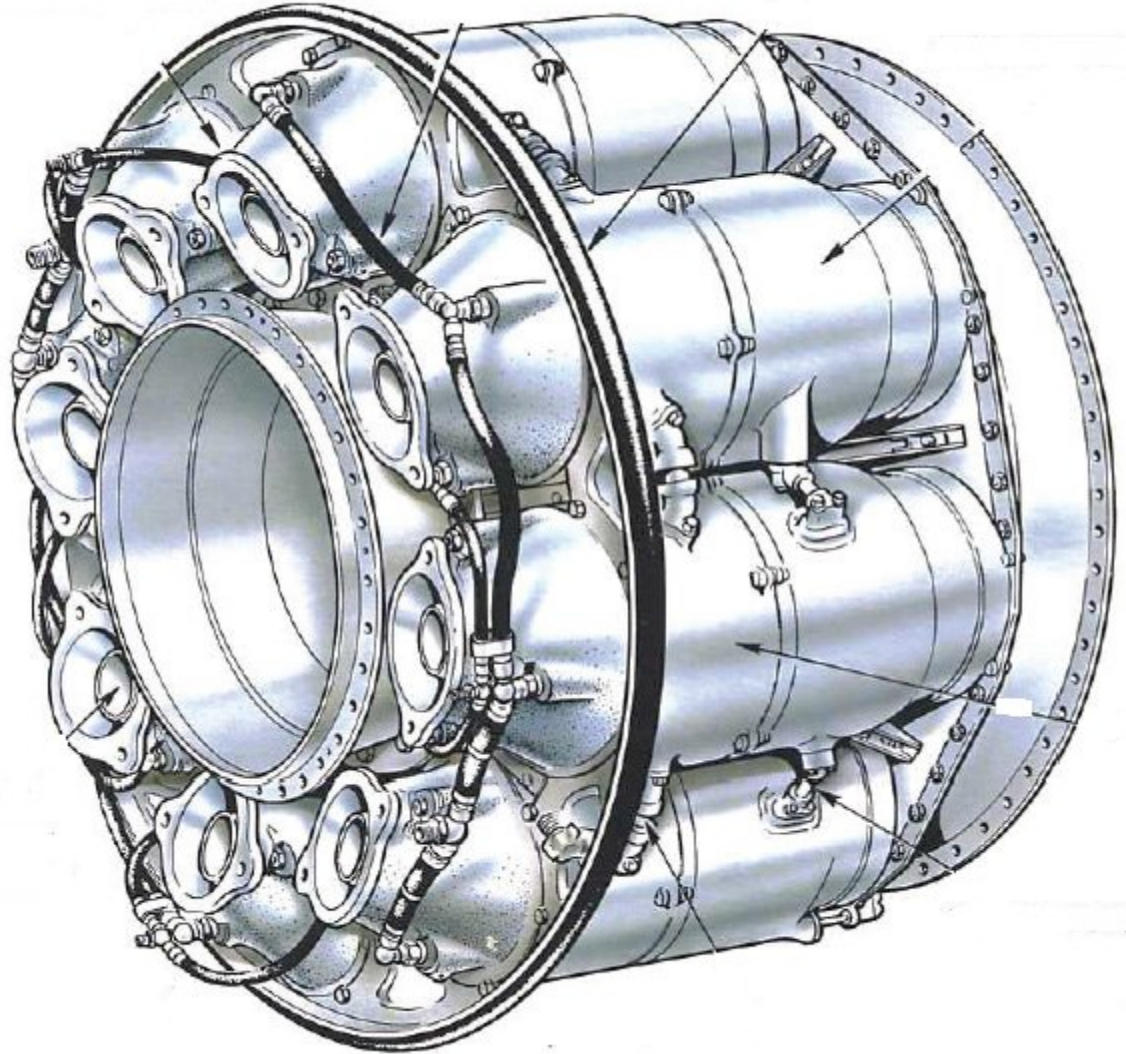

- (a) Multiple combustion chamber.
- o (b) Can type combustion chamber.
- o (c) Annular combustion chamber.

*If choice a is selected set score to 1.*

25. On multi spool engines the overall pressure ratio is....

- o (a) the square of all the individual compressor stages.
- o (b) the sum of all individual compressor stages.
- (c) the multiplication of all the individual compressor stages.

*If choice c is selected set score to 1.*

- 26.** "The nozzle has a constant flow area and gases flow through the nozzle with relatively constant pressure, temperature and speed." (Straight duct)

This best describes...

- (a) an impulse turbine.
- (b) an inlet guide vane.
- (c) a reaction turbine.

*If choice c is selected set score to 1.*

- 27.** By using fir-tree fixing, the blade will be...

- (a) free when the engine is stationary and stiffened in the root when the engine rotates
- (b) fixed to the disk with no clearances.
- (c) free to move slightly at all times to eliminate stresses in the blade root

*If choice a is selected set score to 1.*

- 28.** How is turbine blade creep at a constant rate called?

- (a) Secondary creep.
- (b) Static creep.
- (c) Tertiary creep.

*If choice a is selected set score to 1.*

- 29.** What will happen to the turbine blade when it reaches the tertiary creep stage?

The blade will...

- (a) be under a constant rate of extension.
- (b) become weak.
- (c) eventually break away.

*If choice c is selected set score to 1.*

- 30.** What exhaust nozzle style is described?

"This duct converts much of the heat and pressure energy in the gases into kinetic energy. The gases thus leave the nozzle at high velocity."

- (a) Bellmouth nozzle.
- (b) Subsonic divergent nozzle.
- (c) Convergent nozzle.

*If choice c is selected set score to 1.*

- 31.** The nozzle is fitted at the final end of the exhaust duct and for subsonic aircraft it will be convergent in shape.

That is why the velocity of the turbine discharge gases is relatively...

- (a) cool but it is decreased before they are discharged.
- (b) high but it is decreased before they are discharged.
- (c) low but it is increased before they are discharged.

*If choice c is selected set score to 1.*

- 32.** Blocker door type (cold stream) are mostly used on....

- (a) thrust vectoring nozzles systems.
- (b) supersonic aircraft.
- (c) high by-pass engines.

*If choice c is selected set score to 1.*

- 33.** What are the most common used oil seals?

- (a) Thread (helical type), carbon seals and scrappers.
- (b) Labyrinth, thread (helical type) and carbon seals.
- (c) Labyrinth, scrapper and carbon seals.

*If choice b is selected set score to 1.*

- 34.** What is the advantage to use hydraulic bearings in newer engines?

- (a) Reduces vibrations transmitted to the engine cooling system.
- (b) Increases the lifetime of the bearing.
- (c) Reduces vibrations transmitted to the engine.

*If choice c is selected set score to 1.*

- 35.** The main bearings have the critical function of supporting the main engine rotor.

The number of bearings necessary for proper engine support is, for the most part, determined by...

- (a) length and weight of the engine.
- (b) thrust and weight of the engine.
- (c) life expectancy of the engine between overhaul.

*If choice a is selected set score to 1.*

**36.** What is the most widely used fuel for aircraft with jet engines?

- (a) JP 8
- (b) Jet A / A1
- (c) Jet B

*If choice b is selected set score to 1.*

**37.** What is a difference between Jet A and Jet A-1 fuel?

- (a) Freezing point.
- (b) Fuel density.
- (c) Sulfur mass.

*If choice a is selected set score to 1.*

**38.** Tracer A is an additive to detect leaks....

- (a) in airport fuel systems.
- (b) in aircraft systems.
- (c) in engines.

*If choice a is selected set score to 1.*

**39.** Increasing the flashpoint would reduce the...

- (a) weight of the fuel.
- (b) quantity of the fuel.
- (c) volatile and low-boiling components of the fuel.

*If choice c is selected set score to 1.*

**40.** An oil gear pump delivers oil in the system....

- (a) under pressure.
- (b) to prevent the fuel from freezing.
- (c) to prevent the water in the fuel from freezing.

*If choice a is selected set score to 1.*

**41.** The engine oil tank is a...

- (a) unpressurized container.

- o (b) sump below the engine to return the oil by gravity.
- (c) reservoir for the engine oil system.

*If choice c is selected set score to 1.*

**42.** What is the function of the Fuel / Oil Heat Exchanger?

- o (a) Heating of oil.
- (b) Cooling of oil and heating of fuel.
- o (c) Cooling of fuel.

*If choice b is selected set score to 1.*

**43.** What component in the oil tank will separate the oil from the air?

- o (a) A ball valve.
- (b) The centrifugal breather.
- o (c) The pressure relief valve.

*If choice b is selected set score to 1.*

**44.** The electronic control unit on a gas turbine is a...

- o (a) single channel processor.
- (b) dual channel processor.
- o (c) 4-channel processor.

*If choice b is selected set score to 1.*

**45.** The thrust level request on a FADEC engine is transmitted through a....

- o (a) push/pull control rod system.
- o (b) mechanical cable system.
- (c) TLA resolver.

*If choice c is selected set score to 1.*

**46.** When the fuel flow transmitter is not installed within 24 hours on the system...

- o (a) fill the transmitter with fuel and drain afterwards.
- (b) fill the transmitter with engine oil and drain afterwards.

- (c) it must be covered in a plastic bag.

*If choice b is selected set score to 1.*

**47.** The low pressure fuel pump is a....

- (a) centrifugal pump.
- (b) vane pump.
- (c) gear pump.

*If choice a is selected set score to 1.*

**48.** The fuel manifold carries fuel to spray nozzles.

The spray nozzles spray fuel into the...

- (a) diffuser case.
- (b) combustion chamber.
- (c) first stage of the turbine vanes.

*If choice b is selected set score to 1.*

**49.** The HP fuel pump receives its flow from the...

- (a) fuel nozzles.
- (b) low pressure system (low pressure pump).
- (c) fuel tank booster pumps however only in takeoff.

*If choice b is selected set score to 1.*

**50.** What is the purpose of the accessory cooling system?

The purpose of the accessory cooling system is...

- (a) allowing engine components to heat up to operating temperature.
- (b) to avoid that engine oil exceeds 653 degrees celsius.
- (c) to reduce excessive heat on components, thereby extending life and increasing engine efficiency.

*If choice c is selected set score to 1.*

**51.** The air for the engine anti-icing system is usually taken from the....

- (a) high pressure compressor stage.

- (b) low pressure compressor stage.
- (c) fan module.

*If choice a is selected set score to 1.*

**52.** Compressor Stability Control permits compressor stability...

- (a) only during high power settings
- (b) during cruise power only.
- (c) during starting and engine operation.

*If choice c is selected set score to 1.*

**53.** The engine has sufficient rpm during start-up to accelerate on its own power.

How do you call this speed?

- (a) Idle speed.
- (b) Light-up speed.
- (c) Self-sustaining speed.

*If choice c is selected set score to 1.*

**54.** A common method of coupling the electrical starter drive to the engine is by means of a...

- (a) ratchet on the drive gearbox.
- (b) jaw on the starter.
- (c) direct shaft to high speed shaft.

*If choice b is selected set score to 1.*

**55.** Give the best answer:

When working on the ignition system....

- (a) remove the ignition leads from the exciter box and than remove the ignitors.
- (b) switch off and wait several minutes before removing components from the ignition system.
- (c) switch off and start removing the components from the ignition system.

*If choice b is selected set score to 1.*

**56.** Is the depth of the igniter in the combustion chamber important?

- (a) Yes, but the installation is only important after engine change.

- (b) Yes, the use of correct spacers and gaskets is important.
- o (c) No, because the depth is not critical.

*If choice b is selected set score to 1.*

**57.** "Ignition system voltage is dangerously high. Ignition switch must be in off position before removal of any ignition component." This is a warning.

Why?

- (a) Because it could result in severe injury to personnel
- o (b) The ignition box has to warm up because it extremely cold.
- o (c) Could cause early rotation of the starter.

*If choice a is selected set score to 1.*

**58.** The EGT Harness connects to a terminal block.

From the terminal block, the EGT signal is sent to a...

- o (a) voltage generator, to increase the temperature.
- o (b) resistor to decrease the actual temperature otherwise it can be too high.
- (c) display.

*If choice c is selected set score to 1.*

**59.** On a modern turbofan engine, the engine pressure ratio (EPR) indicating system measures the pressure ratio across the...

- (a) fan.
- o (b) compressor including low pressure.
- o (c) only pressure outlet (exhaust).

*If choice a is selected set score to 1.*

- 60.** The oil pressure transmitter senses the difference between pressure pump delivery pressure and...

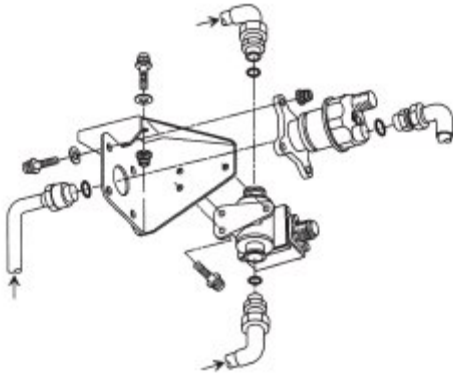

- (a) the gear box pressure.
- o (b) the ISA parameters.
- o (c) the FCOC (Fuel Cooled Oil Cooler).

*If choice a is selected set score to 1.*

- 61.** The engine tachometer N2 system senses engine speed.

It displays the speed on EICAS in....

- o (a) rpm (revolutions per minute).
- (b) percent.
- o (c) engine pounds of thrust.

*If choice b is selected set score to 1.*

- 62.** Engine torque is used to indicate...

- o (a) lateral twist on the engine mouths.
- (b) the power that is developed by a turbo-propeller engine.
- o (c) the power that is developed by a turbo fan engine.

*If choice b is selected set score to 1.*

- 63.** The greatest advantage of the water injection system is...

- (a) the cooling of the turbine.
- o (b) the heating.
- o (c) cooling inlet air.

*If choice a is selected set score to 1.*

**64.** The mass flow rate of air through the engine is depending on the density of the air.

A higher mass flow rate results in...

- (a) a higher engine temperature.
- (b) a greater thrust of the engine.
- (c) a lower thrust output.

*If choice b is selected set score to 1.*

**65.** Which system is normally used on turbo-jet engines to augment the thrust of the engine for short periods?

- (a) Afterburner.
- (b) In cruise.
- (c) Pre-ignition.

*If choice a is selected set score to 1.*

**66.** The propeller is allowed to go to its feather position when the engine is shut down. What type of turbine is this?

- (a) Axial flow turbine.
- (b) Free turbine.
- (c) Coupled turbine.

*If choice b is selected set score to 1.*

**67.** What is the advantage of a parallel spur gear train?

It is...

- (a) mechanically simple but relatively expensive to manufacture.
- (b) mechanically simple and therefore relatively cheap to manufacture.
- (c) mechanically complex but relatively cheap to manufacture.

*If choice b is selected set score to 1.*

**68.** On a typical free turbine turboprop engine the propeller control lever is connected to the...

- (a) constant speed fuel mixing unit.

- (b) propeller governor.
- o (c) fuel control unit.

*If choice b is selected set score to 1.*

**69.** Overspeed is the condition in which the actual engine speed is higher than the desired engine speed set.

How is this prevented?

- (a) By overspeed governor.
- o (b) Centrifugal forces of the fan.
- o (c) Only by throttle being retarded.

*If choice a is selected set score to 1.*

**70.** The drive shaft and flexible coupling system for a helicopter consist of...

- o (a) a direct shaft that can only withstand heavy loads at low RPM.
- (b) a shaft with two flexible couplings attached at each end.
- o (c) a direct chain drive with coupling, that can only withstand heavy loads at low RPM.

*If choice b is selected set score to 1.*

**71.** A short flexible shaft drive system to deliver power to the transmission.

This system is typically installed in a...

- o (a) fighter turbojet aircraft.
- o (b) commercial aircraft fan jet drive system.
- (c) turbine helicopter drive system.

*If choice c is selected set score to 1.*

**72.** The most commonly used freewheeling unit on helicopters is the...

- (a) sprague clutch.
- o (b) centrifugal clutch.
- o (c) wet sink clutch assembly.

*If choice a is selected set score to 1.*

**73.** What is a turbo-shaft engine?

- o (a) A turbine that drives a high speed ultra high bypass compressor.

- (b) A gas turbine engine that delivers power through a rotating shaft.
- o (c) Axial flow compressor with a propeller drive system, used in large commercial aircraft

*If choice b is selected set score to 1.*

**74.** What type of APU load compressor supplies compressed air for the airplane pneumatic system?

- (a) Centrifugal type.
- o (b) High speed fan with a pressure relief valve.
- o (c) Flow counter rotating fan.

*If choice a is selected set score to 1.*

**75.** The APU gearbox is driven by the...

- o (a) external source.
- o (b) compressor section.
- (c) power section.

*If choice c is selected set score to 1.*

**76.** The igniter provides the spark to the...

- o (a) fuel nozzle injector during all phases of APU operation.
- o (b) turbine on APU with a reverse flow combustion chamber.
- (c) combustor chamber.

*If choice c is selected set score to 1.*

**77.** Reverse flow in an APU will...

- o (a) be automatically corrected by the ECU.
- o (b) not cause a shutdown.
- (c) cause a protective shutdown.

*If choice c is selected set score to 1.*

**78.** On very large engines the cowlings and access panels can be so heavy that it will require assistance to open.

How is this performed?

- o (a) It is not required to have access because designers took this into consideration.
- o (b) Simply by the use of more people to raise or lower the section.
- (c) Hydraulic or mechanical assistance.

*If choice c is selected set score to 1.*

**79.** The forward bulkhead is attached to the wing front spar pylon support fitting.

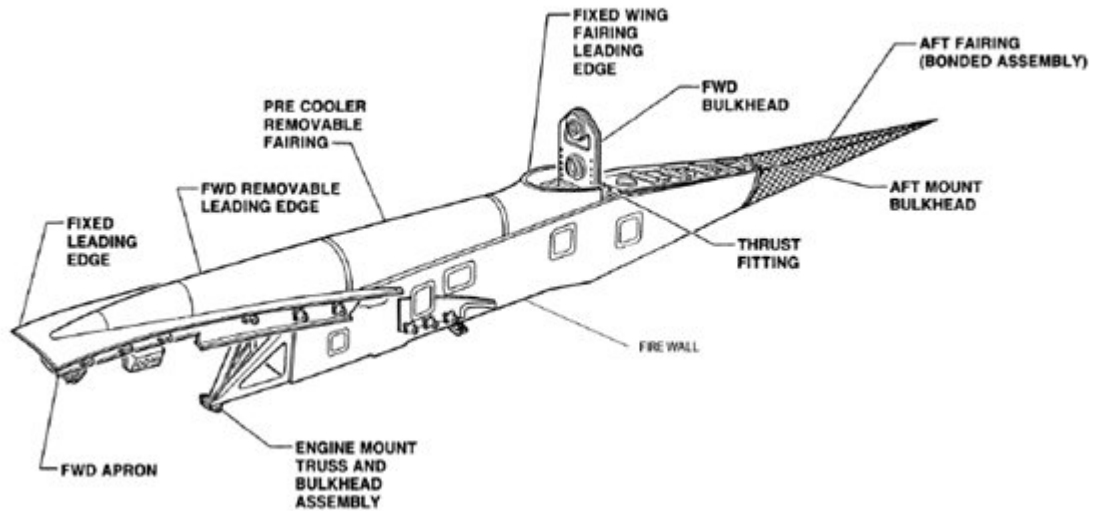

The forward bulkhead fitting transmits...

- (a) only vertical load.
- (b) thrust and provides for engine to grow in length while in operation.
- (c) vertical, side, and torque loads on the pylons to the wing.

*If choice c is selected set score to 1.*

**80.** The fan cowl panels open to provide access to components on the...

- (a) engine fan case
- (b) inlet cowling
- (c) engine combustion chamber

*If choice a is selected set score to 1.*

**81.** The pylon transmits engine loads to the wing through the...

- (a) wing spars, front and rear.
- (b) lower wing surface.
- (c) forward bulkhead and aft mount bulkhead.

*If choice c is selected set score to 1.*

- 82.** This fire detector consists of a sensor and a responder. The sensor tube contains a gas charged core material and helium under pressure.

What system is this?

- (a) Systron-Donner
- o (b) Kidde
- o (c) Fenwall.

*If choice a is selected set score to 1.*

- 83.** A continuous-loop system, which has two wires imbedded in a special ceramic core within an Inconel tube.

What system is this?

- o (a) Fenwall
- o (b) Graviner continuous fire detectors
- (c) Kidde

*If choice c is selected set score to 1.*

- 84.** The fire extinguishing system includes...

- o (a) only protection function
- o (b) a cockpit control switch, fire extinguishing agent containers in the flight deck and an agent distribution system at the wing tip.
- (c) a cockpit control switch, fire extinguishing agent containers, and an agent distribution system

*If choice c is selected set score to 1.*

- 85.** Fire is one of the most dangerous threats to an aircraft.

How are the potential fire zones of all multi engine aircraft which are currently produced, protected?

- o (a) by fire funnels.
- (b) by a fixed fire protection system.
- o (c) by a portable fire protection system.

*If choice b is selected set score to 1.*

- 86.** What major consideration must be observed in positioning the aircraft when preparing for a high power run?

- o (a) Reduce the fuel load because of high power stress and flaps must be retracted

- o (b) Make sure the tail of the aircraft is tie down. Regardless of wind direction.
- (c) Position on firm concrete with the jet exhaust directed away from other aircraft and buildings

*If choice c is selected set score to 1.*

**87.** What is the maximum power setting the pilot can use in an emergency situation?

- o (a) Maximum climb.
- (b) Maximum continuous thrust.
- o (c) Maximum cruise.

*If choice b is selected set score to 1.*

**88.** Trend monitoring is a system of routine comparison of engine performance parameters with a base line of the same parameters.

How is this accomplished?

- o (a) Each Pilots log book entry is compared to the baseline.
- (b) Graphs or curves are used to show trends in changing conditions.
- o (c) Via downloading the post flight report from the on-board maintenance system.

*If choice b is selected set score to 1.*

**89.** One procedure that has improved efficiency is the built-in provision for inspecting the inside of the engine without disassembling it.

This is performed by...

- o (a) large access ports installed through each module of the engine.
- o (b) xray of the internal parts on a regular time frame.
- (c) borescope equipment.

*If choice c is selected set score to 1.*

**90.** Foreign object damage (FOD) comes from many sources.

What are the most common?

- o (a) Ice / hail.
- (b) Taxi ways.
- o (c) Birds.

*If choice b is selected set score to 1.*

**91.** When performing a ground test on a turbine engine....

- o (a) the orientation of the aircraft relative to wind direction is not important.
- o (b) a little tailwind is ok as long as it does not exceed 10 knots.
  
- (c) tailwind is not permitted.

*If choice c is selected set score to 1.*

**92.** When the fuel system is flushed for preservation, there has ....

- o (a) engine oil to be filled in the system.
  
- (b) preservative oil to be filled in the system.
  
- o (c) clean fuel to be filled in the system.

*If choice b is selected set score to 1.*

***If assessment score is 0% to 100% Feedback***